

UDI400

2009 Model Year



WHEELBASES

	A	C	E
GVWR (lb.)	14,250	14,250	14,250
Chassis Weight (lb.)	5,565	5,660	5,740
Front (lb.)	3,780	3,910	3,990
Rear (lb.)	1,785	1,750	1,750
Gross Payload (lb.)*	8,685	8,590	8,510
Wheelbase (in.) ** WB	108.86	131.89	149.41
Cab-to-Rear Axle (in.) CA	83.38	106.42	123.94
Rear Overhang (in.) RO	49.61	49.61	49.61
Overall Length (in.) OL	203.15	226.18	243.70
Turning Radius (ft.)	17.40	20.70	23.00
Typical Body Lengths (ft.)***	10/12	14/16	16/18

*Gross payload capacity equals GVWR minus chassis weight. Installation of specialized equipment or bodies may require frame reinforcement. **Wheelbase selection should be based on specific weight distribution. ***Typical body lengths assume water level load (no specific consideration for driver, passengers, or fuel) to maximize GVWR. Addition of ancillary equipment such as lift gates and refrigeration units not considered in calculations.

ENGINE

	MD-175* 16 valve Turbo/Intercooled Diesel In-line 4 cylinder, Direct-injection
Horsepower	175 hp @ 2,500 rpm
Torque	376 lb. ft. @ 1,600 rpm
Displacement	289 in. ³ (4.728 L)
Cylinder Liner	Dry, replaceable
Fuel System	Electronically controlled, commonrail system
Air Cleaner	11.0 in., dry type
Cold Starting Aid	Automatic electric glow plug
Fan	Viscous type drive

*MD-175 (J05D-TF) is a vendor engine manufactured for Nissan Diesel Motor Company

FRONT AXLE

GAWR	5,360 lb.
Rated Axle Capacity	6,170 lb.
Axle Type	"I" Beam
Suspension	Semi-elliptic leaf springs
Shock Absorbers	Double acting, telescopic type



TRANSMISSION

Aisin A45043L

Automatic, Full electronic control
4 speed overdrive with lockup & park lock

Ratios

1st	3.02
2nd	1.55
3rd	1.00
4th	0.70
Rev.	2.68
R/A Ratio	5.29
Engine rpm @ 65 mph	2,750

STEERING

Integral power steering

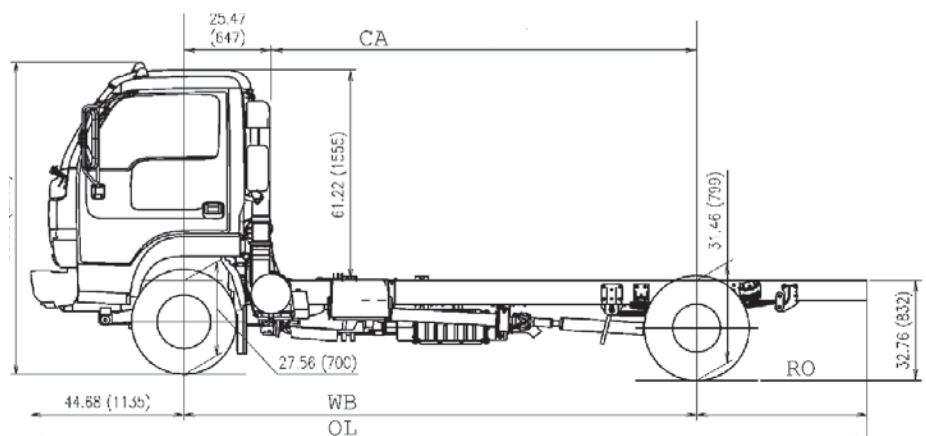
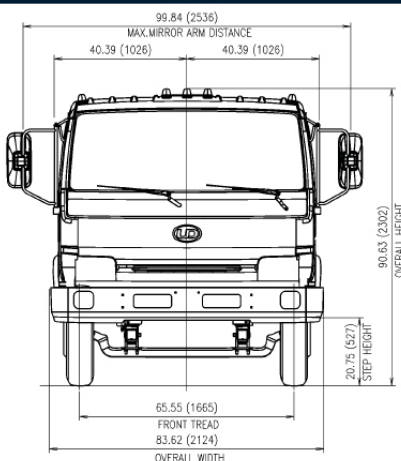

UDI400

2009 Model Year



REAR AXLE

GAWR	9,880 lb.
Rated Axle Capacity	11,500 lb.
Axle Type	Full-floating banjo housing
Suspension	Semi-elliptic leaf springs with auxiliary springs

WHEELS & TIRES

Tires	Front: Single, highway tread Rear: Dual, highway tread 215/85R16 - 10PR (tubeless radial)
Wheels	Steel disc type, 6 hole, 16 x 6.00 in., offset 5.0 in.

BRAKE SYSTEM

Service Brakes	Anti-lock Braking System Dual line, hydraulic brake system with vacuum assist
Front	Ventilated disc brakes
Rear	Internal expanding, dual two leading shoe, self-adjusting drum brakes
Parking Brake	Hand brake lever activating drum at rear of transmission

EXHAUST BRAKE

Electrically controlled, vacuum activated butterfly valve in exhaust pipe

CHASSIS FRAME

Ladder type, channel section side rails

Dimensions (in.)*	7.09 x 2.36 x 0.18
Assembled Width (in.)	29.5
Section Modulus (in.3)**	6.29
Yield Strength (psi)	44,000
RBM (in.-lb.)**	554,000

Rear Inner Reinforcement STD on A & E Wheelbase

*Height x Flange Width x Thickness

**Measured at back-of-cab, specifications based on complete chassis (both rails)

FUEL TANK

Round fuel tank, mounted to right side
Capacity - 33 gallons

CAB

Forward control, steel welded construction,
tilting cab with cab suspension

Air Conditioner	Standard
Assist Handles	Two, driver & passenger
Cab Glass	Windshield, tinted laminated glass - 1900 in. ²
Center Console	Standard
Center Seat	Folding with center console
Driver's Seat	Fore/aft and seat back angle adjustable cloth cover with headrest
Keyless Entry	Standard
Passenger Seat	Fixed with headrest
Power Windows & Door Locks	Standard
Seat Belts	Driver & passenger, 3-point ELR type, center seat w/2-point lap belt
Rearview Mirrors	West coast type, 6.5 x 11 in. with Convex type, 5.8 x 4.3 in.
Steering Column	Tilt & telescopic type
Sun Visors	Driver & passenger
Windshield Wipers	Intermittent & 2 speed

ELECTRICAL EQUIPMENT

Back-up lights
Cigar lighter
Clearance, identification & side marker lights
Day-time running lights
Halogen headlights, 2 lamps
Interior light
License light
Side turn signal lights
Stop/tail lights
Turn signal/hazard lights
Power outlet - 12 volt

INSTRUMENTS

Meters & Gauges
Coolant temperature gauge
Fuel gauge
Speedometer, odometer & trip meter
Tachometer

Warning & Indicator Lights & Buzzer

ABS warning light
Alternator low charge warning light
Automatic transmission:
- Check warning light
- High temperature fluid warning light
- Overdrive cancel indicator light
Brake low vacuum warning light
Engine control system warning light
Engine glow plug indicator light
Exhaust brake indicator light
Hazard warning flasher
High beam indicator light
Low oil pressure warning light
Low brake fluid level warning light
Low coolant level light & buzzer
Parking brake indicator light
Sedimentor warning light
Turn signal indicator lights
Warning lights with burn-out bulb check function
Backup alarm
DPF warning/indicator lights

OTHER OPTIONS

AM/FM stereo radio with CD
Block heater
Rear traction tires

All illustrations, specifications and descriptions in this specification are based on the latest product information available at the time of this publication. The right is reserved to make changes in price, materials, equipment, design, specifications, diagrams and models, and to discontinue models of equipment at any time, without notice and without incurring any obligation whatsoever. For more information on additional options and accessories, contact NISSAN DIESEL AMERICA, INC.

Manufacturer:
NISSAN DIESEL MOTOR CO., LTD.
Saitama, Japan

Distributor:
NISSAN DIESEL AMERICA, INC.
P.O. Box 152034
Irving, Texas 75015-2034
www.udtrucks.com